

OMA V



The OMA linear photodiode array (PDA) from Princeton Instruments is the ideal sensor for high-performance, near-infrared (NIR) spectroscopy. Three models are available with spectral coverage from 800 μm up to 2.2 μm . This InGaAs detector offers outstanding sensitivity with 16-bit digitization and leads the industry with the fastest spectral rate (up to 1800 spectra/sec), lowest system read noise, and software-selectable amplifiers for either high-sensitivity or high-SNR applications. Typical OMA V applications include NIR Raman, emission, and absorbance spectroscopy. Cryogenic cooling minimizes dark noise for long exposure times.

Applications: NIR spectroscopy

Features	Benefits
Response up to 2.2 μm	Ideal for Imaging in NIR region
Cryogenic cooling	Cools the array from -50°C to -100°C to optimize NIR response and minimize dark noise
Software-selectable amplifiers	Exclusive feature provides choice of superior sensitivity or superior signal-to-noise ratio (SNR)
Electronic shutter	Provides integration times from 20 μsec to many minutes
High spectral data rate	Provides up to 1800 spectra/second with 1-MHz digitization
Spectrometer compatibility	Easy integration with industry-standard Acton spectrometers or other leading third-party spectrometers
"USB 2.0 interface" configuration	Seamless, plug-and-play connection to PC notebooks and desktops Easy OEM integration
"PCI interface" configuration	Industry standard for fast data transfer over long distances
WinSpec and PVCAM®	Offers powerful, easy-to-use set of Windows® GUI controls Automates data acquisition, analysis, and display
Linux® drives and SITK™ plug-in for National Instruments' LabVIEW™	Extends system utility

OMA V Specifications

Image sensor	Linear InGaAs photodiode array			
	OMAV:512-1.7		OMAV:1024-1.7	
			OMAV:1024-2.2	
Format	512 x 1, 50 x 500 μm		1024 x 1, 25 x 500 μm	
Spectral Rate	1800 spectra/sec		900 spectra/sec	
	1.7 μm		2.2 μm	
Spectral range	0.8 - 1.7 μm		1.0 - 2.2 μm	
	Minimum	Typical	Minimum	Typical
System read noise				
low gain	5000 e-	6000 e-	7000 e-	8000 e-
high gain	500 e-	650 e-	520 e-	650 e-
	Typical	Maximum	Typical	Maximum
Dark Signal*				
low gain	2.3 ke-/p/s	3 ke-/p/s	1.2 Me-/p/s	1.8 Me-/p/s
high gain	3.2 ke-/p/s	5 ke-/p/s	1.5 Me-/p/s	2.0 Me-/p/s
	All OMA-V models			
	Minimum		Typical	
Spectrometric Well Capacity				
low gain	100 Me-		120 Me-	
high gain	4 Me-		4.5 Me-	
	Minimum	Typical	Maximum	
Nominal Gain				
low gain	1525 e-/ct	1750 e-/ct	2000 e-/ct	
high gain	61 e-/ct	65 e-/ct	76 e-/ct	
Response Non-linearity				
low gain	<1.5%			
high gain	<2.5%			
Response Non-uniformity				
typical	+/- 5%			
maximum	+/- 10%			
Digitization	16 bits			
Scan Rate	1 MHz			
Minimum Exposure time	20 μsec			
Thermostating precision	+/- 0.05 across temperature range			
Operating Temperature	-50°C to -100°C			
Blemish specifications	Grade A: <1% defects, minimum of 5 active pixels between any two inactive pixels			

Notes: All specifications subject to change.
*includes devices dark current @ -100°C looking at a 77K scene.

QE Curve

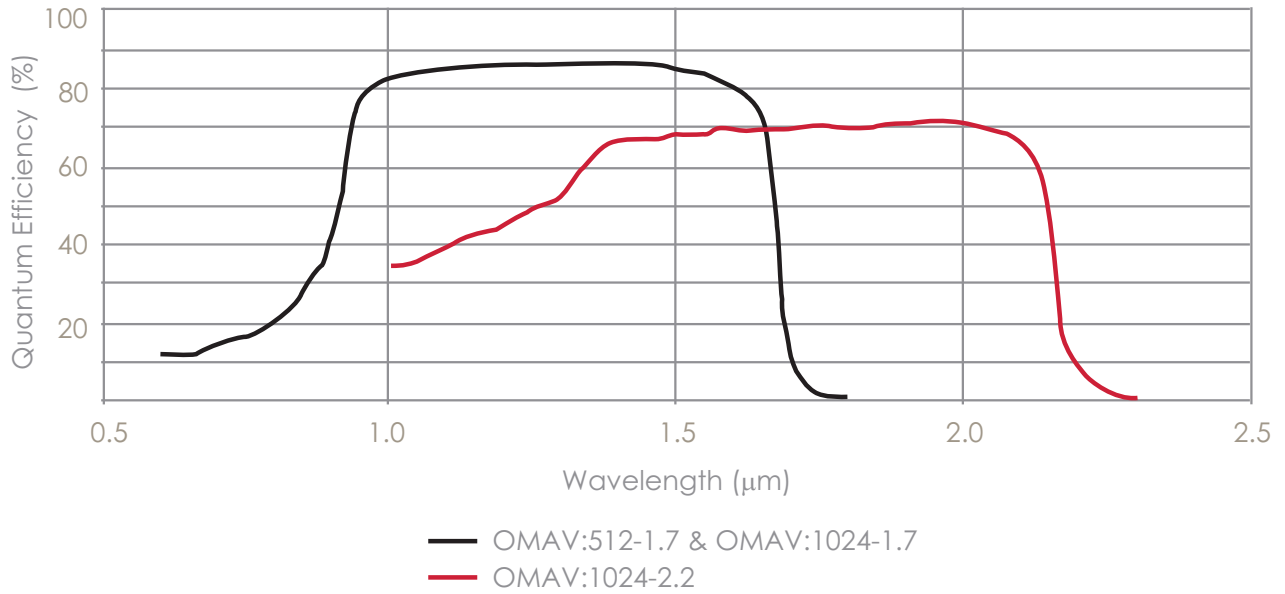

OMA V Drawing

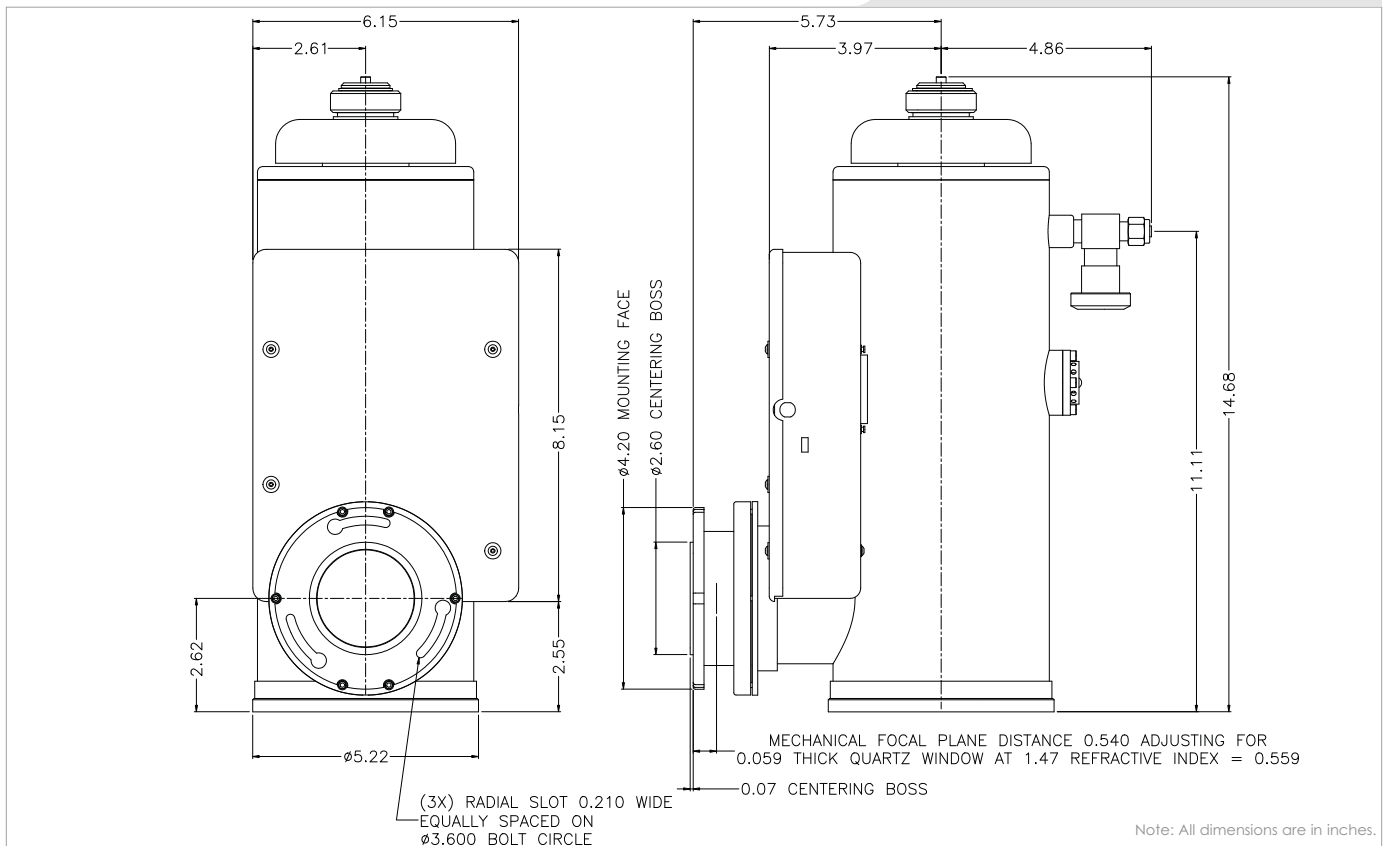

www.piacron.com

email: marketing@piacron.com

USA +1.877.4 PIACRON | Benelux +31 (347) 324989

France +33 (1) 60.86.03.65 | Germany +49 (0) 89.660.779.3

UK +44 (0) 28.88810171 | Asia/Pacific +65.6293.3133

China +86 136 0122 8188 | Japan +81.3.5639.2741